

Purge Economiser -  
Reduces purge loss and  
energy according to  
load requirements.

Accepts dewpoint meter  
signal to cycle on  
dewpoint temperature  
instead of time.

- Designed For- ISO:7183-1986(E)
- Dryer Quality Class - ISO:8573-1:2010(E) class 2
- Pre-Filter Quality Class - ISO:8573-1:2010(E) class 1
- Consistent Dew Point performance
- Noise Level < 70 dBA ■ Pressure Drop < 0.3 kg/cm<sup>2</sup>(g)
- Aluminum Construction
- Free From Corrosion & Scale Formation at Inner and Outer sides
- Uses High Crush Strength Adsorbent Materials



Desiccant Compressed Air Dryers  
**Dryspell Plus**



**Dryspell Plus Desiccant Dryer offers total cleaning solution for lubricated as well as non-lubricated compressed Air.**

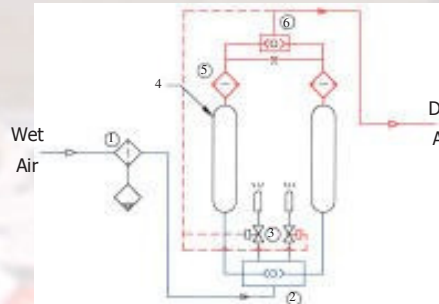

- 1. Pre-filter
- 2. Inlet shuttle valve
- 3. Exhaust valve
- 4. Desiccant tower
- 5. After filter
- 6. Outlet shuttle valve

### Principle of Operation

**Drying Cycle :** Moist air from the compressor is sent through the coalescing filter. Here water & oil coalesces and purges through the auto drain valve. The relatively clean air with water vapour passing through the aluminum drying tower filled with desiccant gets completely dried (up to -40°C PDP) and then passes through a built in after filter (25 micron). The desiccant fines from the towers are completely removed and clean dry air is let out through the outlet port for use.

**Regeneration Cycle:** During the regeneration cycle, the sudden depressurisation brings out water molecule strapped in the Desiccant pores to the surface of the beads. A small portion of dry compressed air from the drying tower then passes over the desiccant through the regeneration orifice built in the Top Block. This results in complete regeneration of the Desiccant.

### Application

- Painting And Powder Coating
- Machine Tool
- Packaging Application
- Auto Garage
- Textile & Garment
- Instrumentation
- Pharmaceutical
- Dental Laboratory
- Rail Vehicles
- Telecomm industry (pressurises its underground cables to repel moisture and avoid shorts)
- Pneumatic control systems
- Feed air for Zeolite type Oxygen and Nitrogen generators
- Truck and Train Air brake systems.

### Market Acceptance

- Excellent Performance
- High Reliability
- Require Less Service Time
- Reasonable Cost
- Low moving components
- Low Maintenance
- Safe Operation
- Global Support

### Specifications

- Maximum Operating Pressure : 16 kg/cm<sup>2</sup>(g)
- Air Inlet Temperature : 38°C Max
- Operating Pressure : 7 kg/cm<sup>2</sup>(g)
- Pre-Filter Rating : 0.01 Micron
- Cycle Time : 4 Minutes
- Operating Voltage : 100-240 VAC 50/60 Hz 1 Ph
- Outlet Conditions : Dry air at -40°C PDP\*
- Purge Loss : 15±1%

\* ISO:8573-1:2010 (E) class -2-

Model	Item Code	Flow scfm **	End Connection BSP	Dimensions (mm)			Weight Kgs	Recommended Accessories	
				H	W	D		Pre filter	Post filter
Dryspell Plus 10	PD237	10	½"	1038	330	150	21	T 100 YEA	T 100 XIA
Dryspell Plus 20	PD238	20	½"	963	371	213	29	T 100 YEA	T 100 XIA
Dryspell Plus 30	PD239	30	½"	1227	371	213	39	T 100 YEA	T 100 XIA
Dryspell Plus 45	PD240	45	½"	999	497	313	49	T 100 YEA	T 100 XIA
Dryspell Plus 60	PD241	60	1"	1192	523	313	61	T 250 YEA	T 250 XIA
Dryspell Plus 100	PD242	100	1"	1603	439	372	106	T 250 YIA	T 250 XIA
Dryspell Plus 125	PD243	125	1"	1913	439	372	119	T 250 YIA	T 250 XIA
Dryspell Plus 200	PD244	200	1½"	1615	449	582	214	T 600 YIA	T 600 XIA
Dryspell Plus 250	PD245	250	1½"	1925	449	582	238	T 600 YIA	T 600 XIA
Dryspell Plus 300	PD246	300	2"	1615	457	764	256	T 600 YIA	T 600 XIA
Dryspell Plus 375	PD247	375	2"	1925	457	764	286	T 600 YIA	T 600 XIA

\*\* As per ISO 7183 option B rated condition

### Inlet Pressure Correction Factor

psi (g)	60	80	100	120	140	160	180
bar (g)	4.1	5.5	6.9	8.3	9.7	11	12.4
Factor	0.65	0.83	1	1.18	1.37	1.52	1.7

### Temperature Correction Factor

°F	90	95	100	105	110	115	120
°C	32	35	38	41	43	46	49
Factor	1.35	1.16	1	0.85	0.74	0.64	0.56

### Dew Point Correction

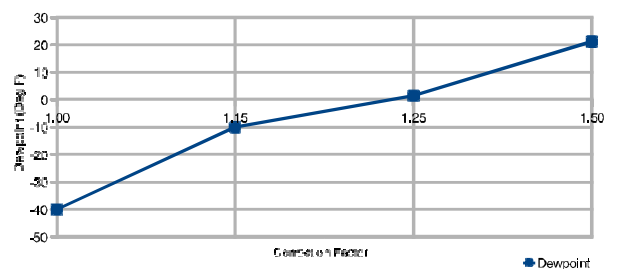

### REACH PNEUMATICS



# 42/2, 6<sup>th</sup> Cross, 5<sup>th</sup> Main, Malleswaram, Bangalore – 560003. Ph.: 080- 23465570, 23469620

e-mail : reachpneumatics@gmail.com Website : www.reachpneumatics.com